

**Trench Field-stop IGBT Discrete**

Parameter	Value	Unit
$V_{CE}$	1200	V
$I_C$	25	A
$V_{CE(sat)}$	1.7	V

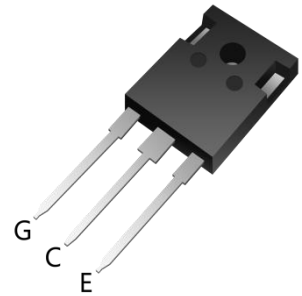
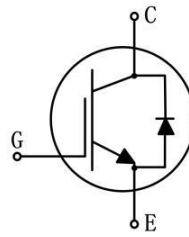

TO-247-3L

**Features**

- Trench and field-stop technology
- Low collector to emitter saturation voltage
- Easy parallel switching capability
- Short circuit withstands time 7μs
- High ruggedness performance

**Applications**

- Inverters
- Motor drives

**Maximum Ratings**

Parameter	Symbol	Value	Unit
Collector-emitter voltage	$V_{CES}$	1200	V
Gate-emitter voltage	$V_{GES}$	±20	V
Continuous collector current( $T_C=25^{\circ}C$ )	$I_C$	50	A
Continuous collector current( $T_C=100^{\circ}C$ )		25	A
Pulsed collector current, tp limited by $T_{vjmax}$	$I_{CM}$	100	A
Diode continuous forward current( $T_C=100^{\circ}C$ )	$I_F$	25	A
Diode maximum current, tp limited by $T_{vjmax}$	$I_{FM}$	100	A
Short circuit withstand time	$t_{sc}$	10	μs
Power dissipation( $T_C=25^{\circ}C$ )	$P_{tot}$	428	W
Power dissipation( $T_C=100^{\circ}C$ )		214	
Operating junction temperature range	$T_{vj}$	-40 to+175	°C
Storage temperature range	$T_{stg}$	-55 to+150	°C

**Thermal Characteristics**

Parameter	Symbol	Value	Unit
Thermal resistance, junction to case for IGBT	$R_{th(j-c)}$	0.35	°C/W
Thermal resistance, junction to case for Diode	$R_{th(j-c)}$	0.9	°C/W
Thermal resistance, junction to ambient	$R_{th(j-a)}$	40	°C/W

**Electrical Characteristics of IGBT ( $T_{vj}=25^{\circ}\text{C}$  unless otherwise specified)**
**Static characteristics**

Parameter	Symbol	Test condition	Value			Unit
			Min.	Typ.	Max.	
Collector-emitter breakdown voltage	$B_{V_{CES}}$	$V_{GE}=0V, I_C=250\mu A$	1200	-	-	V
Collector-emitter leakage current	$I_{CES}$	$V_{CE}=1200V, V_{GE}=0V$	-	-	100	$\mu A$
Gate leakage current, forward	$I_{GES}$	$V_{GE}=\pm 20V, V_{CE}=0V$	-	-	$\pm 100$	nA
Gate-emitter threshold voltage	$V_{GE(th)}$	$V_{GE}=V_{CE}, I_C=1mA (T_J=25^{\circ}\text{C})$	5.8	6.1	6.3	V
Collector-emitter saturation voltage	$V_{CE(sat)}$	$V_{GE}=15V, I_C=25A (T_J=25^{\circ}\text{C})$	-	1.7	-	V
		$V_{GE}=15V, I_C=25A (T_J=175^{\circ}\text{C})$	-	2.3	-	V
Input capacitance	$C_{ies}$	$V_{CE}=30V$	-	2081	-	nF
Output capacitance	$C_{oes}$	$V_{GE}=0V$	-	107	-	pF
Reverse transfer capacitance	$C_{res}$	$f=1\text{MHz}$	-	21	-	pF
Total gate charge	$Q_g$	$V_{CC}=960V V_{GE}=15V I_C=25A$	-	135	-	nC

**Switching Characteristics**

Parameter	Symbol	Test condition	Value			Unit
			Min.	Typ.	Max.	
Turn-on delay time	$t_{d(on)}$	$V_{CC}=600V$ $V_{GE}=15V$ $I_C=25A$ $R_G=10\Omega$ Inductive load	-	33	-	ns
Rise time	$t_r$		-	63	-	ns
Turn-off delay time	$t_{d(off)}$		-	185	-	ns
Fall time	$t_f$		-	61	-	ns
Turn-on energy	$E_{on}$		-	2.1	-	mJ
Turn-off energy	$E_{off}$		-	1.1	-	mJ
Total switching energy	$E_{ts}$		-	3.1	-	mJ
Turn-on delay time	$t_{d(on)}$	$V_{CC}=600V$ $V_{GE}=15V$ $I_C=25A$ $R_G=10\Omega$ Inductive load $T_{vj}=175^{\circ}\text{C}$	-	35	-	ns
Rise time	$t_r$		-	69	-	ns
Turn-off delay time	$t_{d(off)}$		-	207	-	ns
Fall time	$t_f$		-	89	-	ns
Turn-on energy	$E_{on}$		-	3.3	-	mJ
Turn-off energy	$E_{off}$		-	1.5	-	mJ
Total switching energy	$E_{ts}$		-	4.5	-	mJ

**Diode Characteristics**

Parameter	Symbol	Test condition	Values			Unit
			Min.	Typ.	Max.	
Diode forward voltage	$V_F$	$I_F=25A, T_{vj}=25^{\circ}C$	-	2.0	-	V
		$I_F=25A, T_{vj}=175^{\circ}C$	-	1.6	-	V
Diode reverse recovery time	$t_{rr}$	$V_R=600V$	-	311	-	ns
Diode peak reverse recovery current	$I_{rrm}$	$I_F=25A$	-	7.1	-	A
Diode reverse recovery charge	$Q_{rr}$	$diF/dt=-250A/\mu s$	-	1039	-	nC
Diode reverse recovery time	$t_{rr}$	$V_R=600V$	-	482	-	ns
Diode peak reverse recovery current	$I_{rrm}$	$I_F=25A$	-	11.1	-	A
Diode reverse recovery charge	$Q_{rr}$	$diF/dt=-250A/\mu s, T_{vj}=175^{\circ}C$	-	3001	-	nC

**Typical Characteristics**

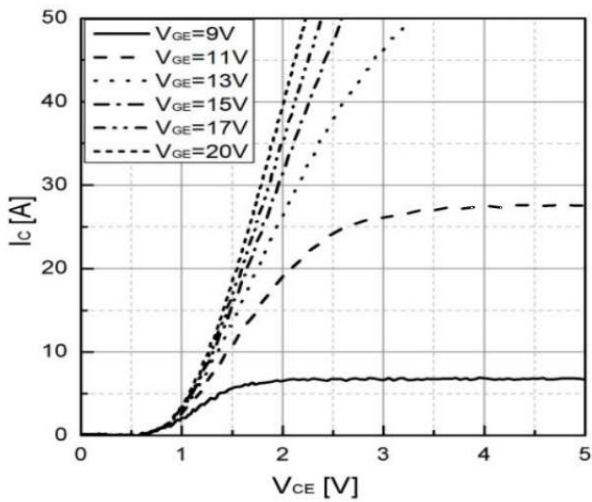

Figure 1. Typical output characteristic ( $T_{vj}=25^{\circ}C$ )

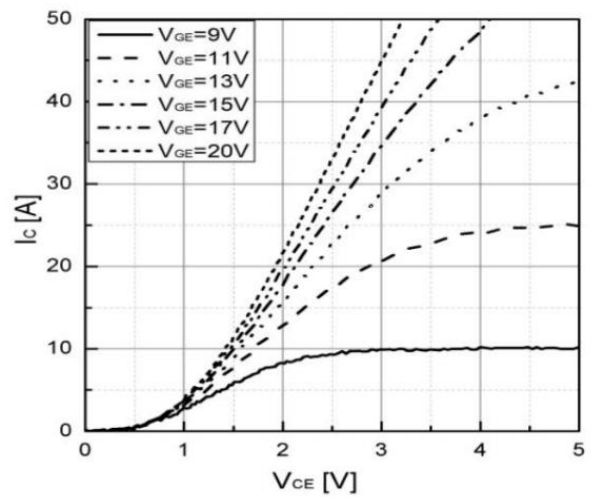

Figure 2. Typical output characteristic ( $T_{vj}=175^{\circ}C$ )

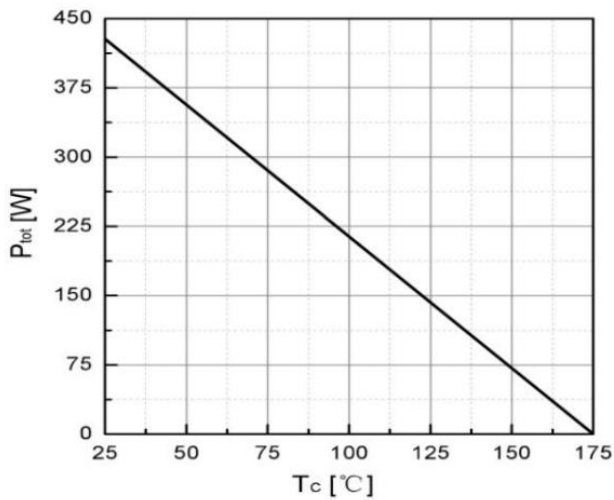

Figure 3. Power dissipation as a function of  $T_c$

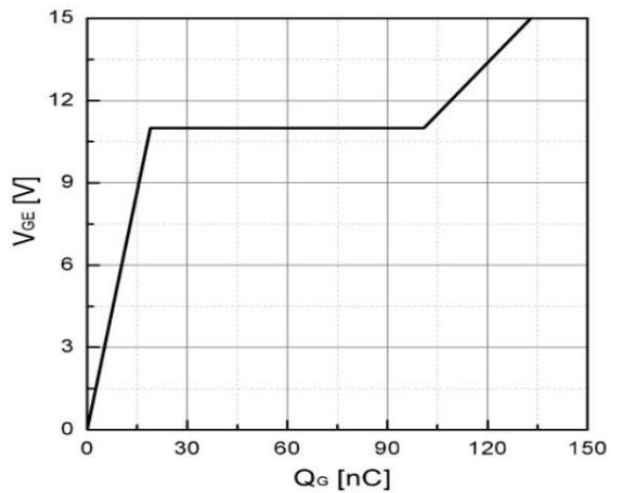

Figure 4. Typical Gate charge

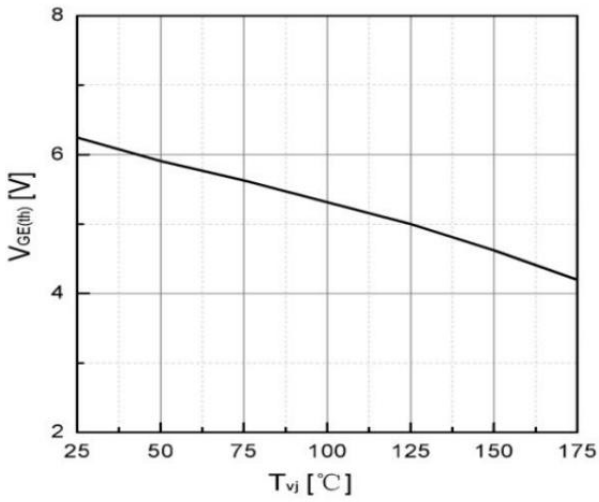

Figure 5. Typical  $V_{GE(th)}$  as a function of  $T_{vj}(I_C=1mA)$

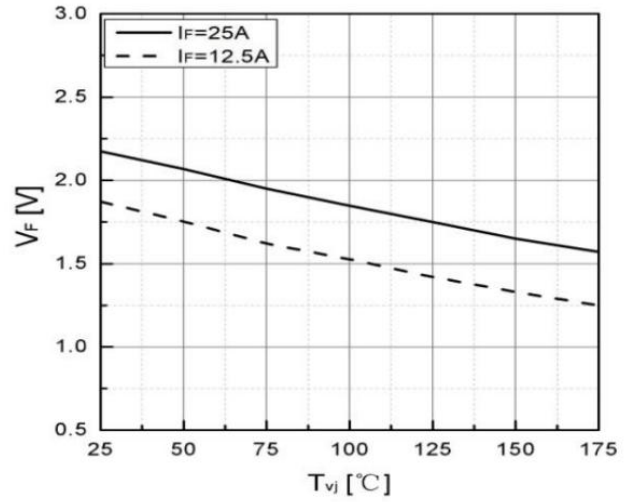

Figure 6. Typical  $V_F$  as a function of  $T_{vj}$

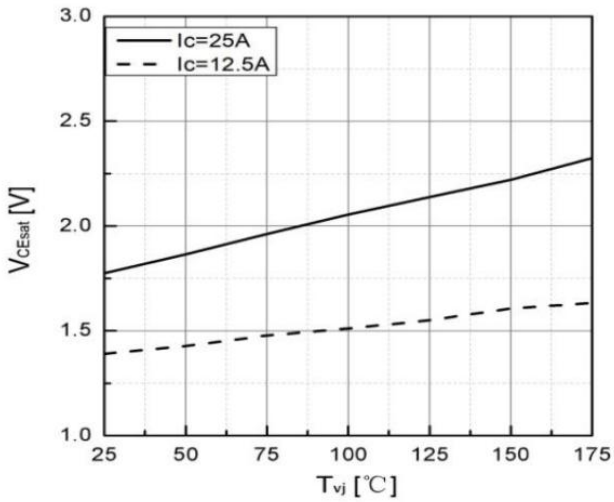

Figure 7. Typical  $V_{CE(sat)}$  as a function of  $T_{vj}$

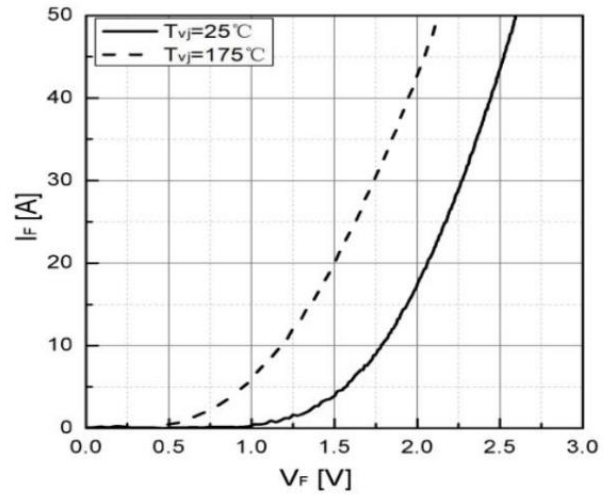

Figure 8. Typical  $I_F$  as a function of  $V_F$

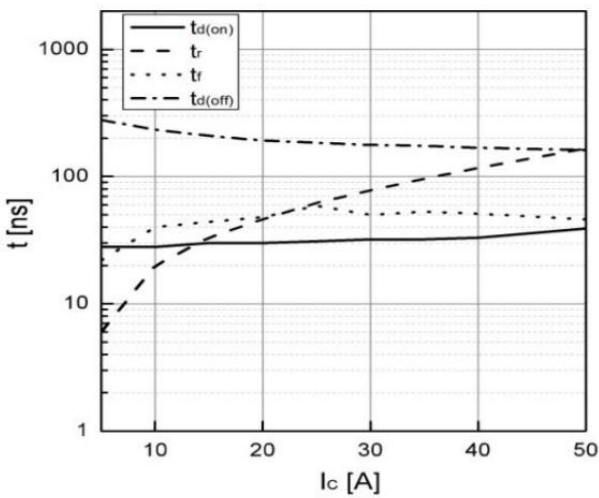

Figure 9. Typical switching time as a function of  $I_C$

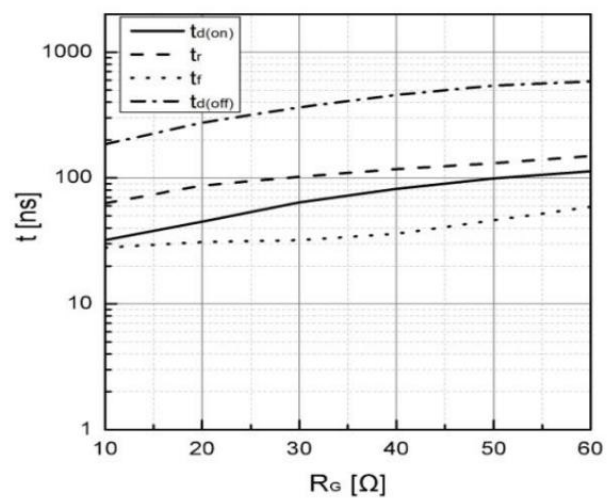

Figure 10. Typical switching times as a function of  $R_G$

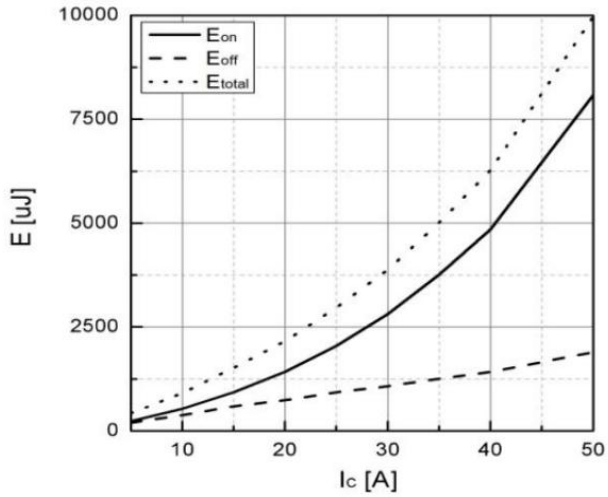

Figure 11. Typical switching energy losses as a function of  $I_c$

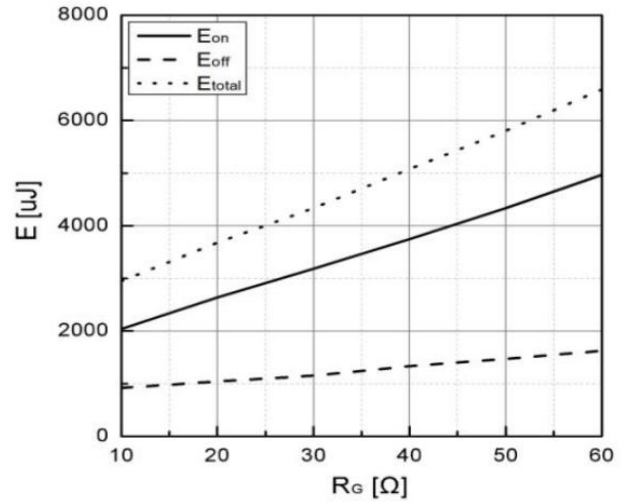

Figure 12. Typical switching energy losses as a function of  $R_G$

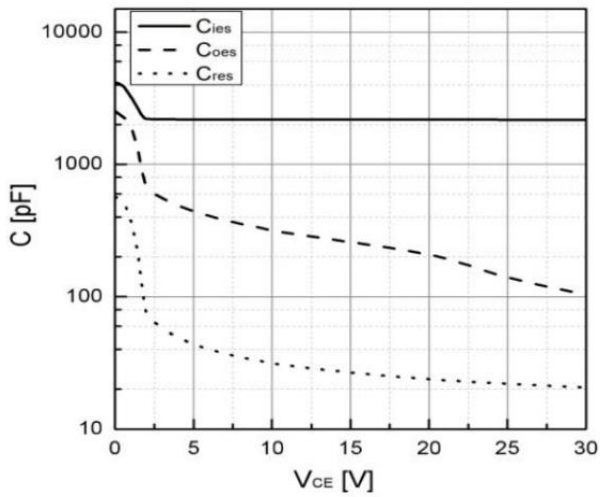

Figure 13. Typical capacitance as a function of  $V_{CE}(f=1\text{Mhz}, V_{GE}=0\text{V})$

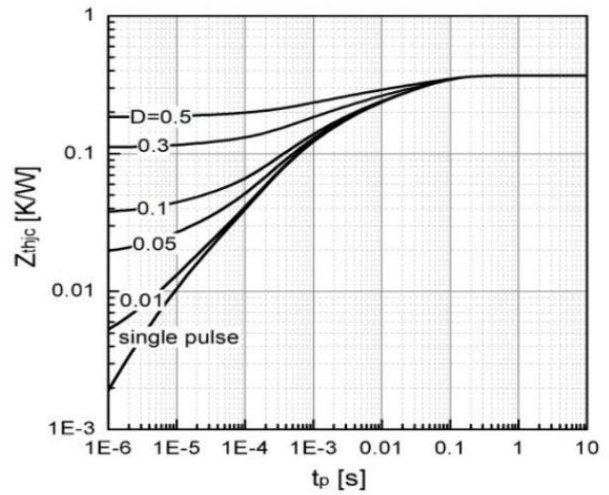
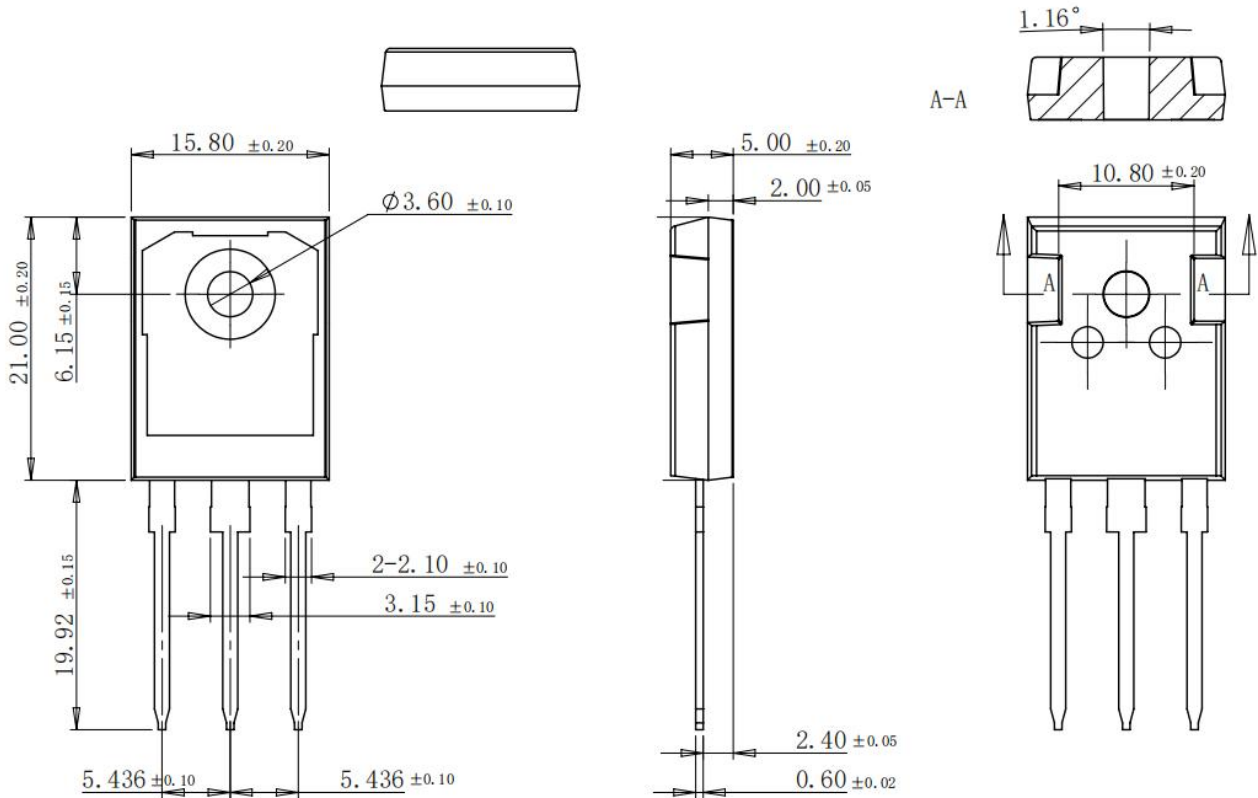

Figure 14. Transient thermal impedance of IGBT

**Package Outlines (Unit: mm)**

**TO-247-3L**



**\*Important Usage Information and Disclaimer**

The specifications of Zhuhai Hypersemi Co., Ltd. products are not guarantees of product characteristics. They reflect typical performance expected in standard applications, which may vary with specific uses. Users must conduct prior testing for their applications and make necessary adjustments.

Users are responsible for the safety of applications utilizing our products and must implement adequate safety measures to prevent physical injury, fire, or other risks in case of product failure. It is the user's duty to ensure that application designs comply with all applicable laws and standards. Our products must not be used in any applications where a product failure could reasonably result in personal injury, unless specifically authorized in a signed document by Zhuhai Hypersemi Co., Ltd.

No representations or warranties are made regarding the accuracy or completeness of this information, including any claims of non-infringement of third-party intellectual property rights. Zhuhai Hypersemi Co., Ltd. assumes no liability for any applications or uses of its products and does not grant any licenses to its intellectual property rights or those of others. We also make no claims regarding non-infringement of third-party intellectual property rights that may arise from applications.

Due to technical requirements, our products may contain hazardous substances. For details, please contact your nearest sales office. This document replaces all previous information and may be updated. We reserve the right to make changes.